

CleanZone XP

LED Explosion Proof Food Light



Model B



Model B2



Model B2



Certifications:

- ◆ Marking ATEX
 - ◆ Ex II3 G Ex ec IIC T3C Gc
 - ◆ Ex II2 Ex tb IIIC T135°C Db IP66
- ◆ Marking IECEX
 - ◆ Ex ec IIC T3C GC
 - ◆ Ex tb IIIC T135°C Db IP66
- ◆ Ingress Protection: IP66
- ◆ Marking UL844 (North American)
 - ◆ Class I, Division 2, Groups A, B, C, D
 - ◆ Class II, Division 1, Groups E, F, G
 - ◆ Class II, Division 2, Groups F, G
 - ◆ Class III
- ◆ Ambient Temperature: -40°C to 60°C (-40°F to 140°F)
- ◆ Food Safety: NSF

Standard Materials:

- ◆ Housing: Aluminum
- ◆ Lens: PC
- ◆ Hardware: Stainless steel

Due to continuous improvement and innovation, product appearance and specifications may change without notice. Actual performance may differ as a result of end-user environment and application.

TOLL-FREE: 888-410-5337 | FAX: 614-868-5344 | © 2026 SpecGrade

www.SpecGrade.com

LED Explosion Proof Food Light - CleanZone XP

Key Features:

- ① Dimmable and battery backup function is available.
- ② High-quality SMT LED and Meanwell driver.
- ③ Heavy-duty and high impact resistance.
- ④ Replaceable LED board and drivers.
- ⑤ Integrated junction box for driver.
- ⑥ Marine rating powder coated finish treatment.
- ⑦ Various installation ways for different applications.
- ⑧ Polycarbonate lens for making different beam angles.

Additional Features:

- ◆ High efficacy up to 140 lumens per watt.
- ◆ 5-year warranty.
- ◆ Wide beam angle of 120°.
- ◆ Three connection cable entry points makes installation and configuration more reasonable.
- ◆ Low temperature applications to -40°C (-40°F) and high temperature up to 60°C (140°F).

Catalog Number Logic:

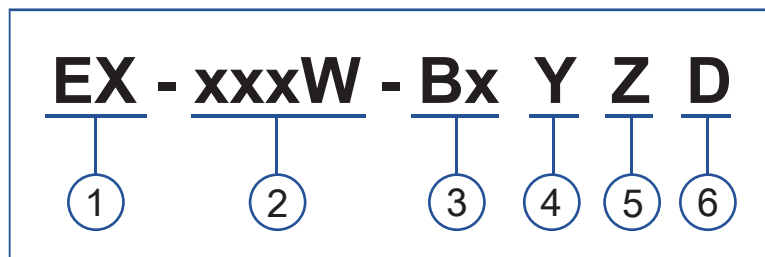

- ① **PRODUCT CATEGORY**
 - ◆ Explosion proof light
- ② **WATTAGE**
 - ◆ 20W-200W
- ③ **PRODUCT SERIES**
 - ◆ B ◆ B2 ◆ B3
- ④ **DIMMING OPTION**
 - ◆ D= Dimmable
 - ◆ N= Non-dimmable
- ⑤ **CCT**
 - ◆ From 2200K to 7000K
 - ◆ 22=2200K, 30=3000K, ..., 70=7000K
- ⑥ **BEAM ANGLE**
 - ◆ D120= 120°

Light Distribution: Beam Angle: 120°

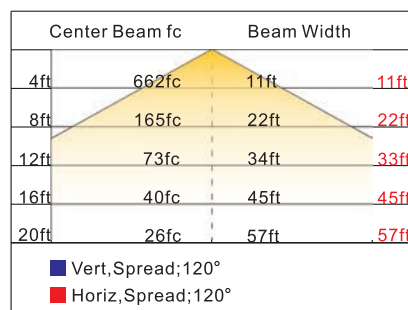

LED Explosion Proof Food Light - CleanZone XP

Key Features:

Model	Wattage	Lumens (lm)	Operating Voltage	CCT	CRI
EX-20W B2YZD A-F	20W	2,800	AC100-277V (by IC)/DC12-48V	2200K-7000K	80
EX-40W B2YZD A-F	40W	5,600			
EX-60W BYZD A-F	60W	8,400			
EX-80W BYZD A-F	80W	11,200			
EX-100W B3YZD A-F	100W	14,000			
EX-120W B3YZD A-F	120W	16,800			
EX-150W B3YZD A-F	150W	21,000			
EX-200W B3YZD A-F	200W	28,000			

Packing Information:

Model	Quantity/Carton	Packing Size	Net Weight	Gross Weight
B2	1 PCS	12.60x12.60x11.81inch	3.25 kg/ 7.16 lbs	5.25 kg/ 11.57 lbs
B	1 PCS	15.98x15.98x9.65inch	3.5 kg/ 7.72 lbs	4.5 kg/ 9.92 lbs
B3	1 PCS	20.28x20.28x14.57inch	8.25 kg/ 18.19 lbs	10.25 kg/ 22.60 lbs

Dimensions:

Model B

Diffusion Option A

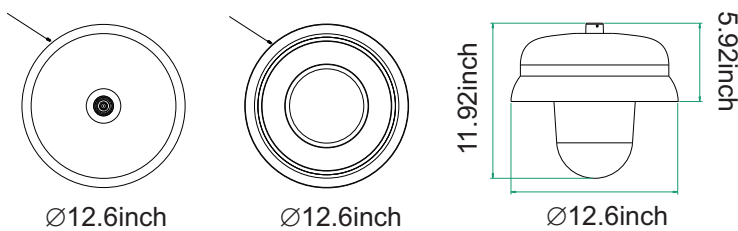

Diffusion Option B

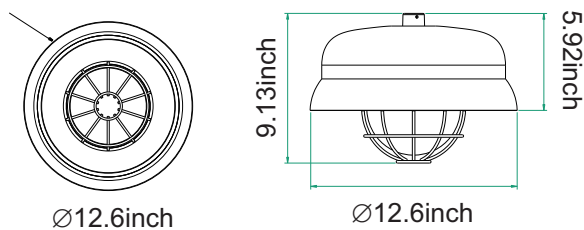

Diffusion Option C

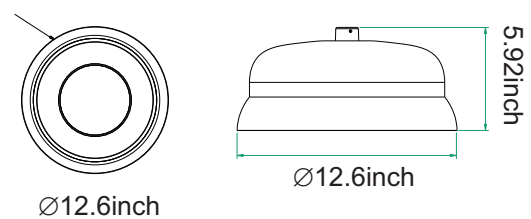

LED Explosion Proof Food Light - CleanZone XP

Model B2

Diffusion Option A

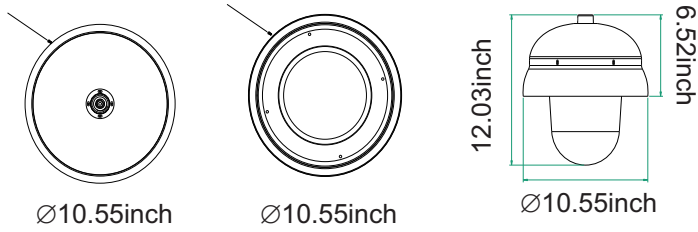

Diffusion Option B

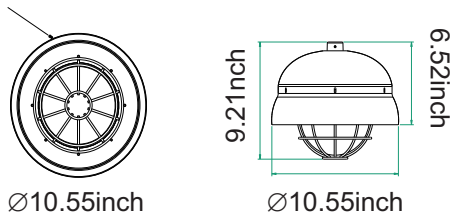

Diffusion Option C

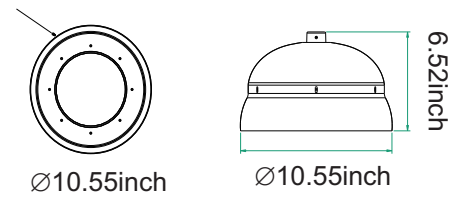

Model B3

Diffusion Option A

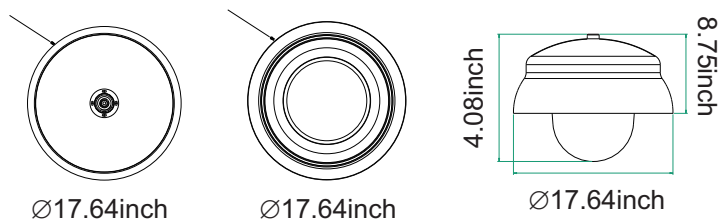

Diffusion Option B

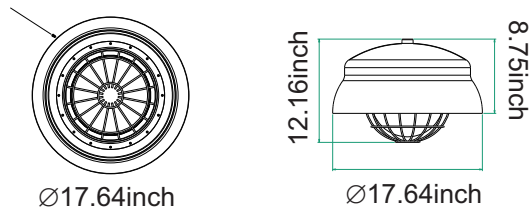

Diffusion Option C

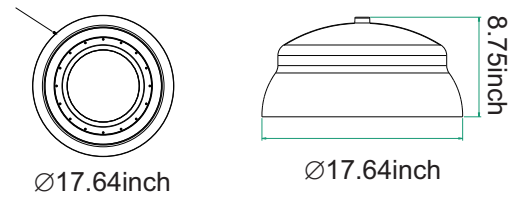

Mounting:

Pole Pendant Mounting:

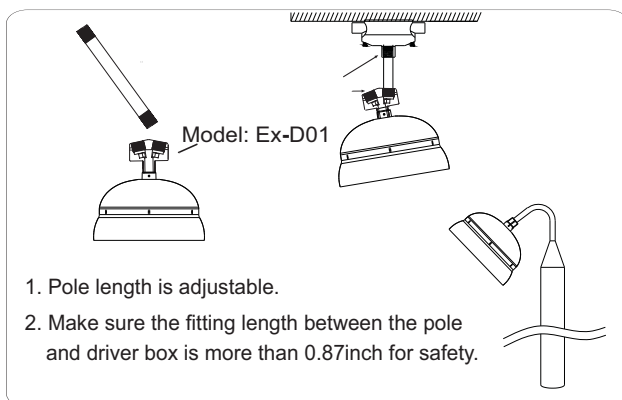

Hook Pendant Mounting:

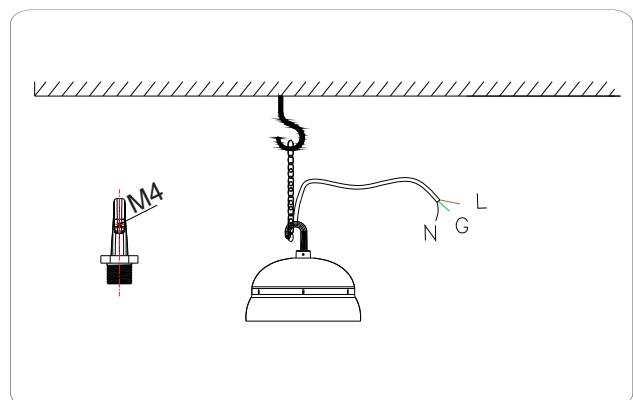

LED Explosion Proof Food Light - CleanZone XP

Stanchion Pendant Mounting:

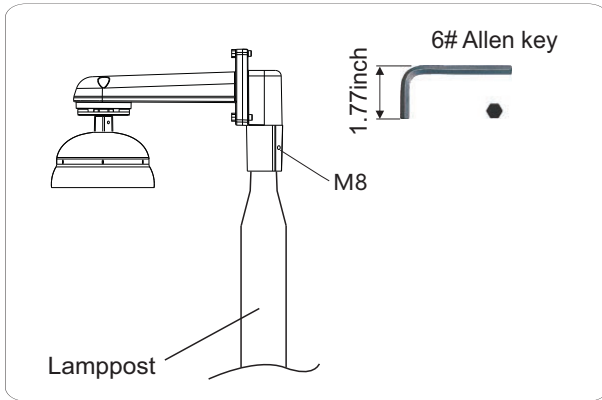

Wall Mounting to Junction Box:

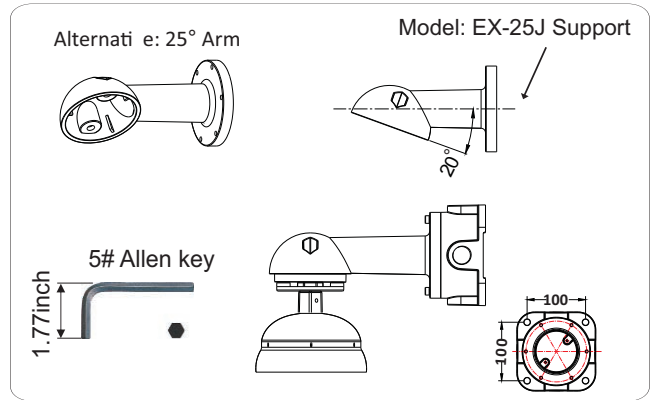

Applications:

- Food and alcohol industry: flour and fine particle production and storage, food and distilling production, alcohol industry, etc.

